

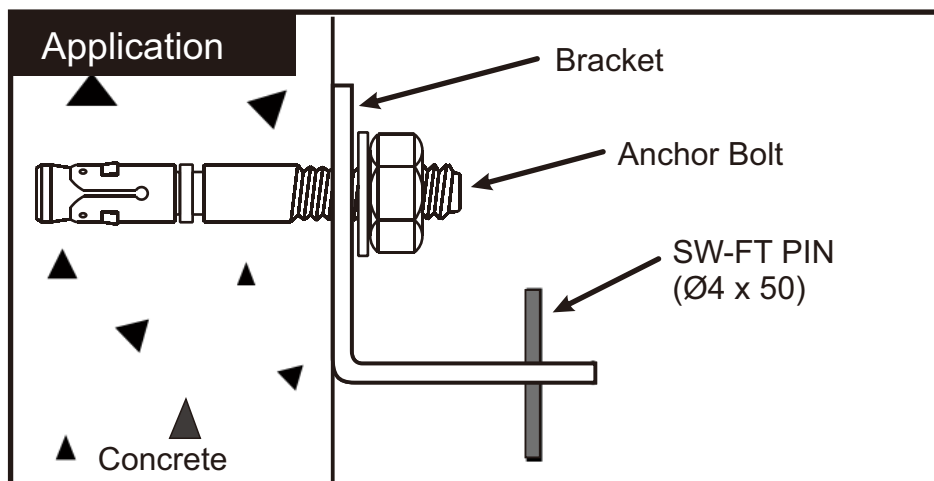

Advantages:

- Fit Pin fixing design could ensure all the
 - S.S. Pin are vertical after installation, minimize the problem of different workmanship quality
- S.S. Pin could be held tightly in the bracket
 - without epoxy during installation progress, usage of epoxy could be reduced

Material:
Stainless steel 304/316



For the tailor-made design, please contact us and place order in advance

More Information 

SUNWAY SW-FT Fit Pin Fixing (SW-FT)

Traditional Pin-Bracket Fixing

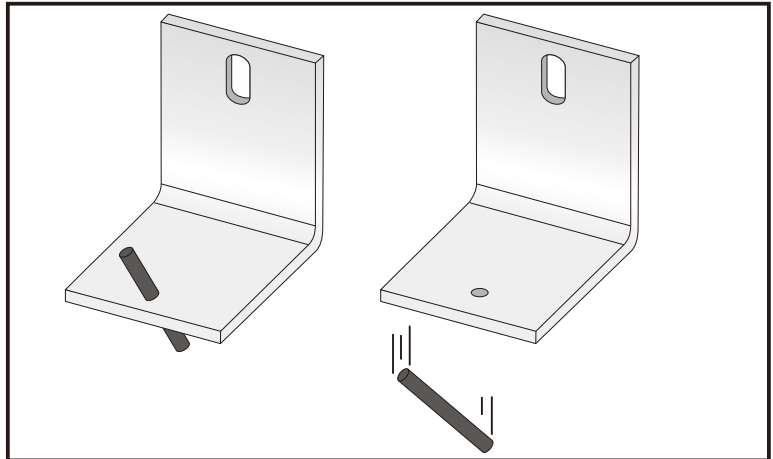
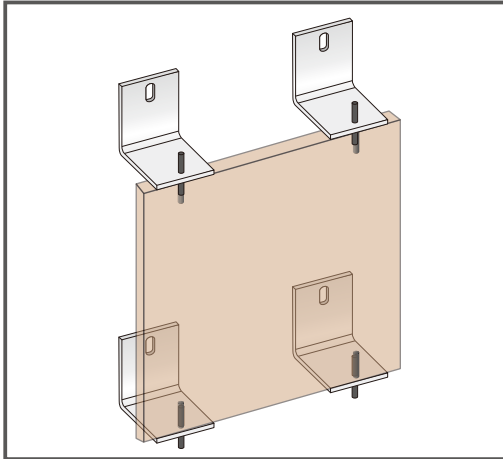

Pin may not be vertically fixed in the bracket or may be lost during the installation process.

SUNWAY SW-FT Fit Pin Fixing

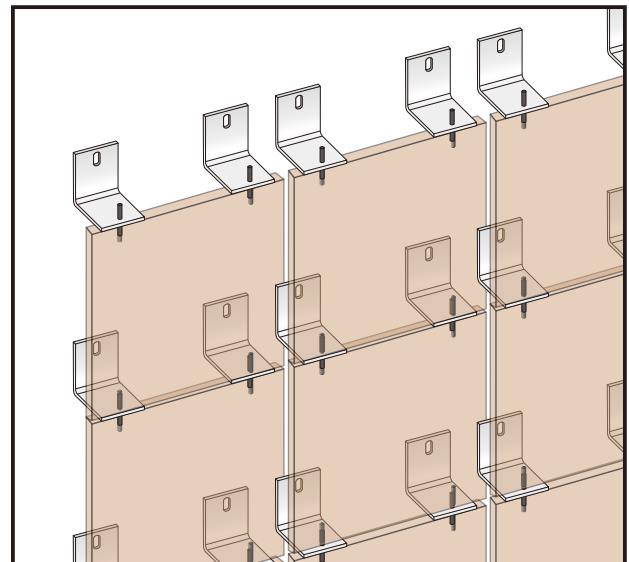
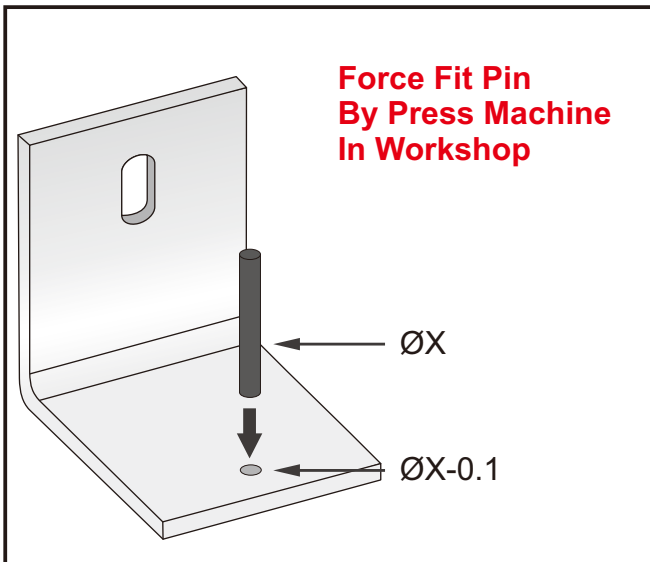

The fit pin is fixed by press machine in workshop. This ensure all the S.S. pins are vertical, in a good shape and could be held tightly in the bracket.

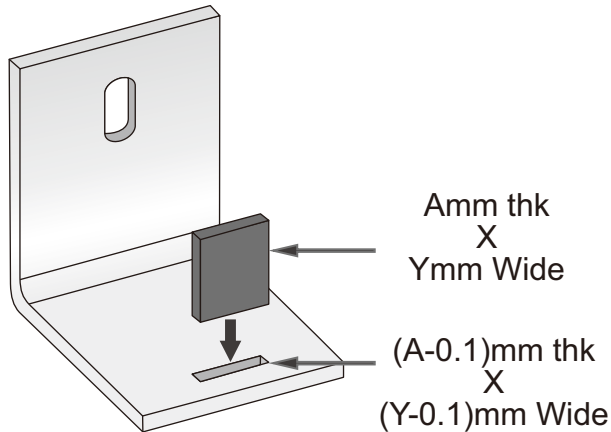

Material:
Stainless steel 304/316

Advantages:

- Ensure all the S.S. Plates are vertical, in a good shape and could be held tightly in the bracket
- Minimize the problem of different workmanship quality

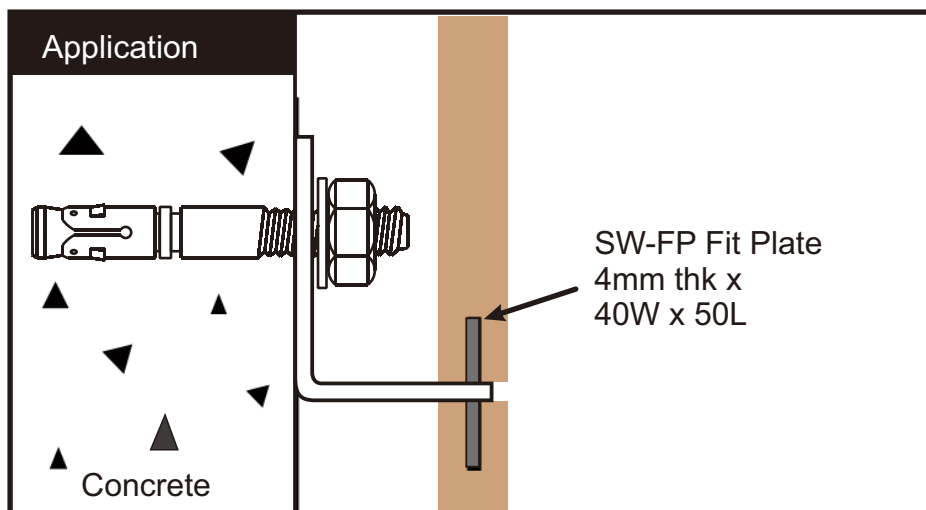

For the tailor-made design, please contact us and place order in advance

More Information 

SUNWAY SW-FP Fit Plate Fixing (SW-FP)

Traditional T-Bracket/Kurt-Bracket Fixing

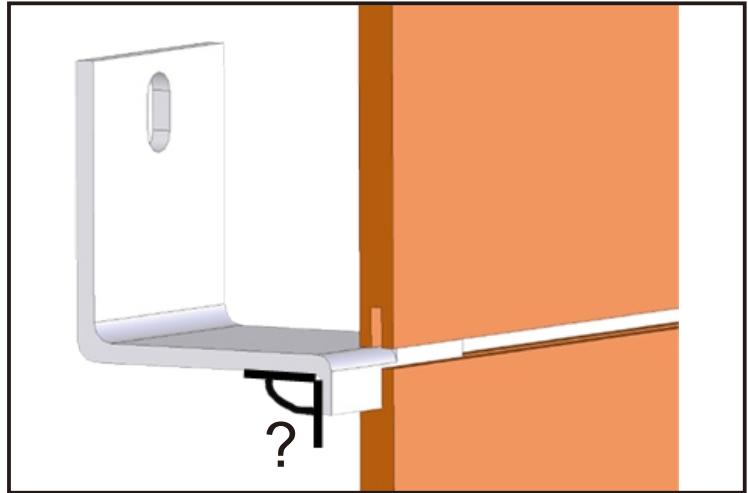
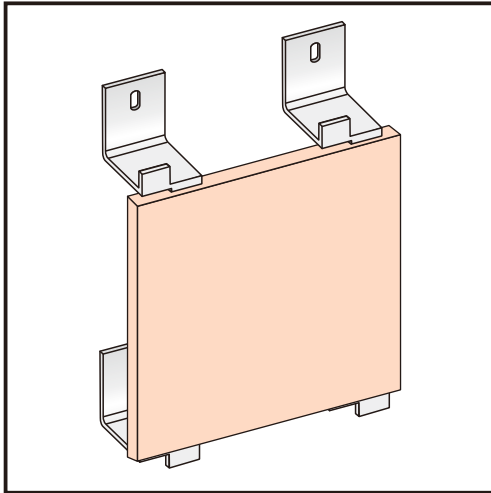

If the fold angle is not 90 degree, a gap may formed between two stone panels. This may affect the appearance of the whole stone facade.

SUNWAY SW-FP Fit Plate Fixing

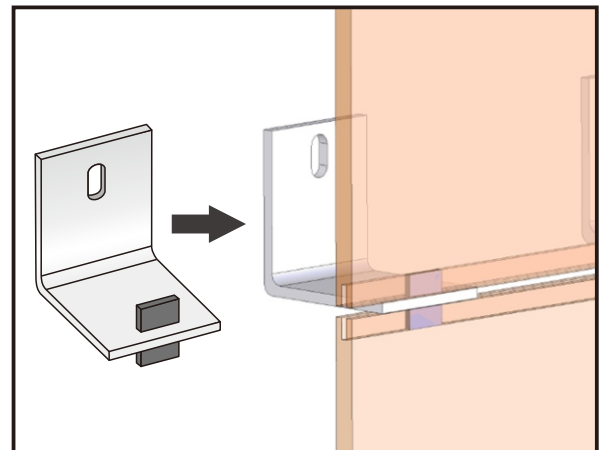
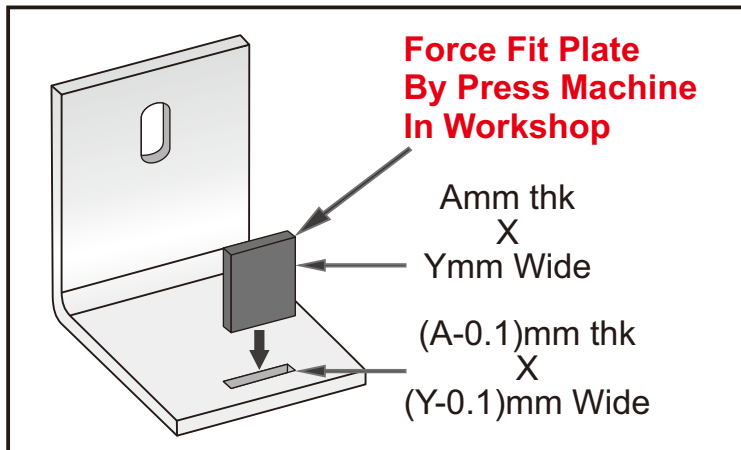

The fit plate is fixed by press machine in workshop. This ensure all the S.S. plate are vertical, in a good shape and could be held tightly in the bracket.